

Features

- Bushing mount
- Optional center tap and rear shaft extension
- Optional AR lug feature
- Gangable with common or concentric shafts
- High torque available
- Non-standard features and specifications available

- RoHS compliant*

3540/3541 - Precision Potentiometer

Product Dimensions

3540S-1/3541H-1

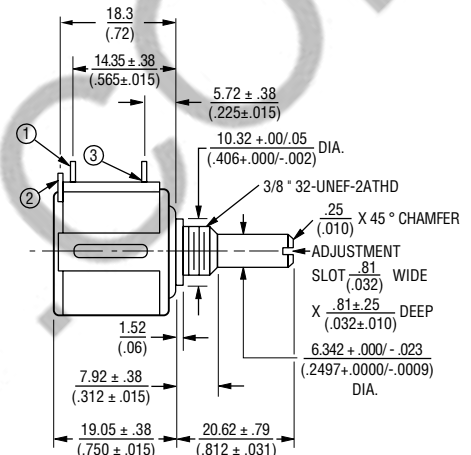

OPTIONAL ANTIROTATION LUG
(-91) 1.42 X .50 ON 7.4 RADIUS.
LENGTH 1.27 FROM MOUNTING SURFACE.
(SUGGESTED PANEL HOLE 1.6 DIA.)

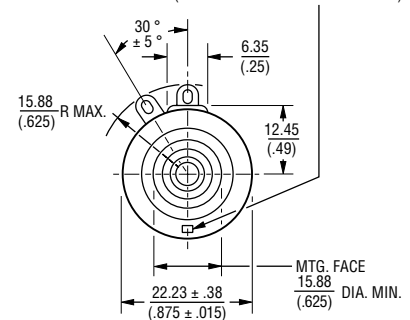

TOLERANCES: EXCEPT WHERE NOTED

DECIMALS: XX ± .25 (.010), .XXX ± .13 (.005)

FRACTIONS: ± 1/64

DIMENSIONS: MM (IN.)

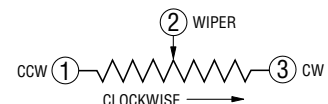

BOLDFACE LISTINGS ARE IN STOCK AND READILY AVAILABLE THROUGH DISTRIBUTION.

FOR OTHER OPTIONS CONSULT FACTORY.

ROHS IDENTIFIER:
L = COMPLIANT

*RoHS Directive 2002/95/EC Jan 27, 2003 including Annex. Specifications are subject to change without notice.

Customers should verify actual device performance in their specific applications.

Electrical Characteristics¹

	3540 Wirewound Element	3541 Hybritron® Element
Standard Resistance Range.....	100 to 100 K ohms.....	1 K to 100 K ohms
Total Resistance Tolerance.....	±5 %.....	±10 %
Independent Linearity.....	±0.25 %.....	±0.25 %
Effective Electrical Angle.....	3600° +10°, -0°.....	3600° +10°, -0°
Absolute Minimum Resistance/.....	1 ohm or 0.1 % maximum.....	0.2 % maximum
Minimum Voltage.....	(whichever is greater)	
Noise/Output Smoothness.....	100 ohms ENR maximum.....	0.1 % maximum
Dielectric Withstanding Voltage (MIL-STD-202, Method 301)		
Sea Level.....	1,000 VAC minimum.....	1,000 VAC minimum
Power Rating (Voltage Limited By Power Dissipation or 447 VAC, Whichever Is Less)		
+70 °C.....	2 watts.....	2 watts
+125 °C.....	0 watt.....	0 watt
Insulation Resistance (500 VDC).....	1,000 megohms minimum.....	1,000 megohms minimum
Resolution.....	See recommended part nos.	Essentially infinite

Environmental Characteristics¹

Operating Temperature Range.....	-40 °C to +125 °C.....	-40 °C to +125 °C
Storage Temperature Range.....	-55 °C to +125 °C.....	-55 °C to +125 °C
Temperature Coefficient Over		
Storage Temperature Range ²	±50 ppm/°C maximum/unit.....	±100 ppm/°C maximum/unit
Vibration.....	15 G.....	15 G
Wiper Bounce.....	0.1 millisecond maximum.....	0.1 millisecond maximum
Shock.....	50 G.....	50 G
Wiper Bounce.....	0.1 millisecond maximum.....	0.1 millisecond maximum
Load Life.....	1,000 hours, 2 watts.....	1,000 hours, 2 watts
Total Resistance Shift.....	±2 %.....	±5 %
Rotational Life (No Load).....	1,000,000 shaft revolutions ²	5,000,000 shaft revolutions ²
Total Resistance Shift.....	±5 % maximum.....	±5 % maximum
Moisture Resistance (MIL-STD-202, Method 103, Condition B)		
Total Resistance Shift.....	±2 % maximum.....	±5 % maximum
IP Rating.....	IP 40.....	IP 40

Mechanical Characteristics¹

Stop Strength.....	53 N-cm (75 oz.-in.) minimum
Mechanical Angle.....	3600° +10°, -0°
Torque	
Starting & Running @ +25 °C.....	0.35 N-cm (0.5 oz.-in.) max.
Starting & Running @ -40 °C.....	1.76 N-cm (2.5 oz.-in.) max.
Mounting.....	170-200 N-cm (15-18 lb.-in.) max.
Shaft Runout.....	0.08 mm (0.003 in.) T.I.R.
Lateral Runout.....	0.13 mm (0.005 in.) T.I.R.
Shaft End Play.....	0.30 mm (0.012 in.) T.I.R.
Shaft Radial Play.....	0.08 mm (0.003 in.) T.I.R.
Pilot Diameter Runout.....	0.08 mm (0.003 in.) T.I.R.
Backlash.....	1.0° maximum
Weight.....	Approximately 21 gm
Terminals.....	Gold-plated solder lugs
Soldering Condition	
Manual Soldering.....	96.5Sn/3.0Ag/0.5Cu solid wire or no-clean rosin cored wire; 370 °C (700 °F) max. for 3 seconds
Wave Soldering.....	96.5Sn/3.0Ag/0.5Cu solder with no-clean flux; 260 °C (500 °F) max. for 5 seconds
Wash processes.....	Not recommended
Marking.....	Manufacturer's name and part number, resistance value and tolerance, linearity tolerance, wiring diagram, and date code
Ganging (Multiple Section Pots.).....	2 cups maximum
Hardware.....	One lockwasher (H-37-2) and one mounting nut (H-38-2) is shipped with each potentiometer.

¹At room ambient: +25 °C nominal and 50 % relative humidity nominal, except as noted.

²Consult manufacturer for complete specification details.

Recommended Part Numbers

Part Number	Resistance (Ω)	Resolution
3540S-1-201L	200	.042
3540S-1-501L	500	.031
3540S-1-102L	1,000	.027
3540S-1-202L	2,000	.021
3540S-1-502L	5,000	.021
3540S-1-103L	10,000	.019
3540S-1-203L	20,000	.014
3540S-1-503L	50,000	.011
3540S-1-104L	100,000	.008

Part Number	Resistance (Ω)
3541H-1-102L	1,000
3541H-1-202L	2,000
3541H-1-502L	5,000
3541H-1-103L	10,000
3541H-1-203L	20,000
3541H-1-503L	50,000
3541H-1-104L	100,000

3540/3541 - Precision Potentiometer

BOURNS®

Panel Thickness Dimensions

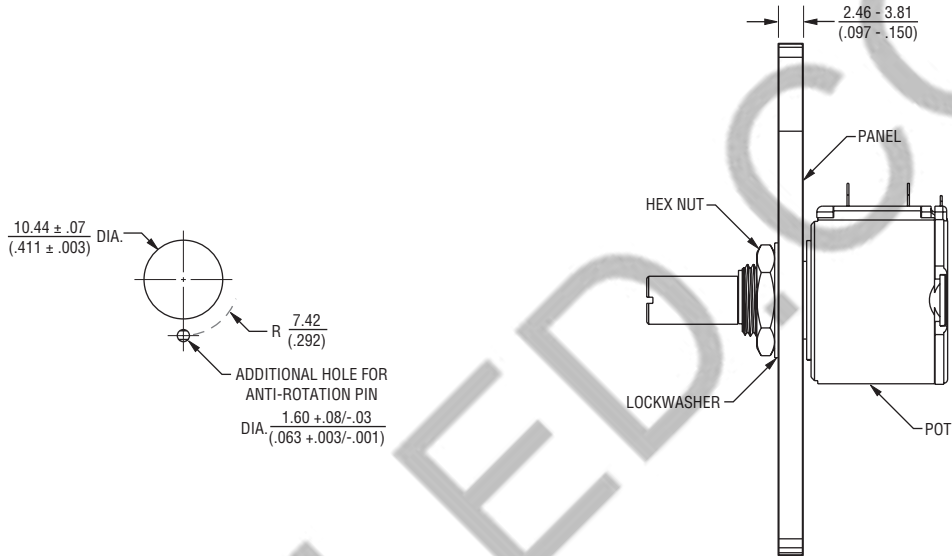

Anti-rotation pin hole is shown at six o'clock position for reference only. The actual location is determined by the customer's application. Refer to the front view of the potentiometer to see the location of the optional A/R pin.

Panel thickness and hole diameters are recommended for best fit. However, customers may adjust the dimensions to suit their specific application.

DIMENSIONS: $\frac{\text{MM}}{\text{(INCHES)}}$ TOLERANCES: $\pm \frac{0.127}{(.005)}$

REV. 10/11

"Hybritron" is a registered trademark of Bourns, Inc.
Specifications are subject to change without notice.
Customers should verify actual device performance in their specific applications.